



Westar Medical Products, Inc.



ELEGANCE & DISTINCTION Westar introduces affordable luxury. Always famous for reliability and efficiency, Westar adds beauty and comfort to the dental operator. The classic look of wood and leather will move you to the forefront of modern operator design.

ART AND SCIENCE



2006 Catalog

Phone: 425/290-3945 ♦ Watts: 800/499-3945 ♦ Fax: 425/356-2961
6600 Merrill Creek Parkway, Suite 206 ♦ Everett, WA 98203
Email: westar_medical@msn.com ♦ Website: www.westarmedicalproducts.com

Warranty

All Westar products are warranted to be free from defects in material and workmanship only. This warranty extends for a period of three (3) years unless otherwise stated. No other warranties are expressed or implied. Any and all claims against this product shall be made in writing within this time period. Remedy for correction is limited to repair or replacement of parts as determined appropriate by Westar Medical Products, Inc. This warranty shall be voided if product is misused or is not properly installed or maintained. The warranty does not cover damage resulting from the use of cleaning, disinfecting, or sterilization chemicals or processes. The warranty also does not cover orings, light bulbs, or other consumables. This warranty does not cover any labor or shipping charges to the factory. Any consequential damage will not be covered. Damage caused by accident in shipping and handling is not covered by this warranty. Cuts and scratches in upholstery or equipment are not covered by this warranty. Upholstery packages are warranted to be free from defects in workmanship for a period of two (2) months. All lights and their parts are warranted to be free from defects in material and workmanship for a period of one (1) year. The Vortex valve specifically has a lifetime warranty. Labor to remove, reinstall or service the valve is not covered by this warranty. All Westar products are subject to continuous development, therefore product specifications may differ from those outlined in this publication. Your Westar dealer will always have the latest information.

- ❖ Extended Three Year Warranty on each chair or delivery system
Retail Price: \$400 Order# 1008

Order Information

Please include the following information with your purchase order:

- ❖ Catalog part number
- ❖ Description of product
- ❖ Desired Quantity
- ❖ Color pattern, name and number
- ❖ Shipping address
- ❖ Shipment method preferred
- ❖ Purchase Order number
- ❖ Telephone and fax number

Terms

- ❖ All prices quoted herein are in United States dollars and are subject to change without notice.
- ❖ All prices listed in this catalog are suggested retail.
- ❖ On approved accounts terms are 1%-10 day, Net 30 from date of invoice. All other accounts will be sold on a C. O. D. or prepay basis until credit is approved.

Returns

All Returning merchandise must have prior factory authorization and must be shipped freight prepaid. A restocking fee of 15% may be charged on returned items approved for credit. Any custom product deviating from a standard product order, including but not limited to upholstery, can not be returned for credit consideration. A copy of the original invoice or proof of purchase must accompany the authorized return. Have serial numbers and order numbers ready when requesting returns. An R. M. A.# must be written clearly on the outside of the box.

Factory Labor Charges

- ❖ Technical Labor
Retail Price: \$160 per hour Order# 1007
- ❖ Factory installation of a Westar Delivery System on a Westar chair
Retail Price: \$150 per unit Order# 1009

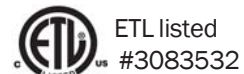

California Bureau of Home Furnishings and Thermal Insulation License #MFG 111108
City of Los Angeles Building and Safety Approval # M-980072

All rights reserved. Printed in the U. S. A.

FDA Registered #9060261

Table of Contents

❖ Warranty, Order Information and Terms	2
❖ Table Of Contents	3
❖ Representative Territory Map	4
❖ The Story of Westar	5
❖ Excursion and Nautica Delivery Systems and Packages	6-7
❖ Nautica 5000 Delivery Systems	8-9
❖ Constellation Delivery Systems	10-11
❖ Professional Delivery Systems	12-13
❖ 5000 Hydraulic Patient Chair and pictures of factory options	14-15
❖ Electromechanical Patient Chairs	16-17
❖ OS III	18-19
❖ Orthodontic Equipment, Chairs, Carts, Panel mounts	20-22
❖ Miscellaneous Unit Parts and Delivery Systems	23-25
❖ Cart Delivery Systems	26-27
❖ Lights	28
❖ Intraoral Handpiece Illumination Systems (Fiber optics)	29
❖ Stools	30-31
❖ Upholstery Packages	32-33
❖ Junction box layout (Contoured)	34
❖ Dimensional drawings and specifications for Delivery Systems	35

Representative Territories

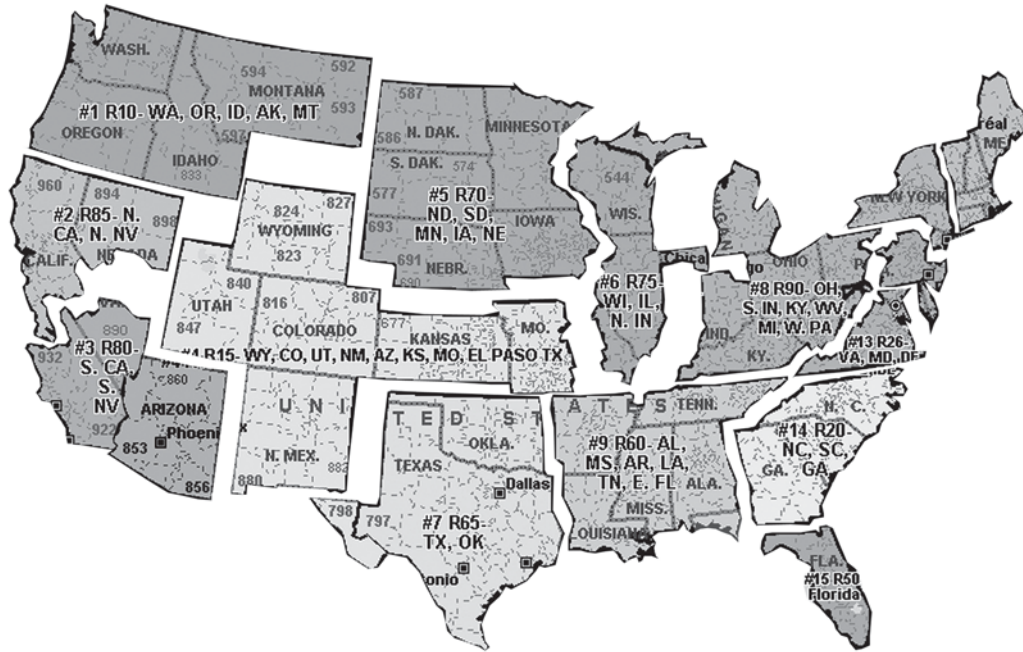

#1 WA, OR, ID, AK, MT
R10: Tammy Norton
 Northwest Dental Sales
 P.O. Box 87459
 Vancouver, WA 98687
 Phone: 360/833-9430
 Fax: 360/833-9010
 Cell: 360/901-6100
 NorthwestDentalSales@comcast.net

#2 Northern California, Northern NV
R85: Westar is looking for qualified professional representatives in this territory. If you are interested please call us at 800/499-3945.

#3 Southern California, Southern NV, AZ
R80: Dan Fijan
 Independent Representative
 15624 Janine Drive
 Whittier, CA 90603
 Phone: 562/777-4508
 Fax: 562/947-8302
 Cell: 562/777-4508
 fijand@msn.com

#4 WY, UT, CO, NM, KS, MO
R15: Westar is looking for qualified professional representatives in this territory. If you are interested please call us at 800/499-3945.

#5 ND, SD, NE, MN, IA
R70: Donald Smith
 Diversified Tech Sales
 8012 Erie Avenue
 Chanhassen, MN 55317
 Phone: 952/934-6824
 Fax: 952/934-6824
 Cell: 612/810-8129
 donaldsmith@msn.com

#6 WI, IL, N. Indiana
R75: Westar is looking for qualified professional representatives in this territory. If you are interested please call us at 800/499-3945.

#7 TX, OK
R65: Paul Wood
 Wood Dental Sales
 5906 Flintshire Court
 Arlington, TX 76017
 Phone: 817/478-9666
 Fax: 817/478-9666
 Cell: 817/690-5194
 paulwood@comcast.net

#8 OH, S. IN, KY, WV, W. PA, MI
R90: Burt Lawrence
 Mid Central Marketing
 13844 Bainwick Dr. N.W.
 Pickerington, OH 43147
 Phone: 740/927-1321
 Fax: 740/927-1321
 Cell: 614/296-2565
 blaw9708@earthlink.net

#9 AL, MS, AR, LA, TN, FL panhandle
R60: Thurston Yates
 Mid-South Dental Sales, Inc.
 110 Tchefuncte Drive
 Covington, LA 70433
 Phone: 985/867-8500
 Fax: 985/867-8506
 Cell: 985/789-2526
 midsodontalsales@bellsouth.net

#10 MA, ME, VT, NH, RI, CT
R05: Rudy Mourlot
 Nasa International
 239 Howard Street
 North Boro, MA 01532
 Phone: 508/393-2078
 Fax: 508/393-3130
 Cell: 617/510-8889
 rudy_mourlot@hotmail.com

#11 New York, New Jersey
R01: Chris Mourlot
 Nasa International
 239 Howard Street
 North Boro, MA 01532
 Phone: 508/393-2078
 Fax: 508/393-3130
 Cell: 617/899-5209
 cmourlot@charter.net

#12 East PA, S. NJ
R25: Westar is looking for qualified professional representatives in this territory. If you are interested please call us at 800/499-3945

#13 VA, MD, DE
R26: Jim Lee
 JPM Enterprises
 11901 Parallele Road
 Bowie, MD 20720
 Phone: 301/262-5332
 Fax: 301/805-4656
 Cell: 301/346-6298
 jlee70@hotmail.com

#14 N. Carolina, S. Carolina, Georgia
R20: Richard LaCasse
 LaCasse Sales and Marketing
 19 Driver Court
 Hendersonville, NC 28739
 Phone: 828/891-9832
 Fax: 828/891-9832
 Cell: 770/846-5191
 richl47@aol.com

#15 Florida (less pan handle)
R50: Dick Sourbier
 Independent Representative
 1711 Emerald Cove Drive
 Cape Coral, FL 33991
 Phone: 239/772-5240
 Fax: 208/988-4878
 Cell: 239/770-1591
 rjssales@earthlink.net

#25 International
R35: Cheryl Balda
 Westar Medical Products, Inc.
 6600 Merrill Creek Parkway
 Everett, WA 98203
 Phone: 425/290-3945
 Fax: 425/356-2961
 westar_medical@msn.com

The Story of Westar

1992 Westar gives birth to the concept "ECONOMY WITHOUT COMPROMISE", and starts production of dental equipment in a 600 square foot garage in Everett, Washington. The first contract was to manufacture patient chairs, stools, and wooden crates for another mid-sized dental equipment manufacturer.

In the summer of 1992 Westar decided they could provide better quality products to the industry so they designed and began to manufacture the "all steel" W2000 patient chair. With attractive styling, quality construction, and affordable pricing, this chair's durable design has provided the time tested reliability Westar customers have come to expect. Over the next year and a half Westar also developed a line of dental upholstery kits for the Pelton & Crane Chairman and Coachman, Adec 1005 and 1020, Belmont Advantage and Healthco Celebrity, in addition to numerous other kits. Westar took on additional building space over the next few years at various sites around Everett to accommodate its rapid growth.

1994 Westar introduced the W2005 Orthodontics chair to fill the need for an economical chair in the orthodontics field. To increase efficiency Westar implemented a computerized inventory control system to lower inventory levels, decrease lead times and improve product quality. Investments were made to create a "lights out" automated system including Computer Numerically Controlled Machines. This was done to streamline production and supply a growing line of dependable, precise, and economical dental products. Westar also added five new models to the existing line of chairs; the OSII oral-surgery chair, the OSII oral-surgery table, the W2010, W2020 and W2001 patient chairs.

1995 ADA requires increased asepsis control in the dental office. Development of the Westar Vortex pinch style valve with its "Lifetime Warranty" was initiated to satisfy this new requirement. The resulting valve has the unique capability of allowing the dental block to be purged with most anti microbial agents and yet not harm the valve, including use of 1 to 10 bleach solution. The unique design isolates the cleaning solution from brass or other metal components. This advanced asepsis system is being evaluated by several other manufactures.

1997 Engineers at Westar had expanded product development to include delivery systems. In addition to the standard over the patient units the Westar delivery system line now includes Euro/ Continental style deliveries as well as Front or Rear rotational deliveries for both the control head or assistant package. These systems come in both deluxe and economy styles and reflect mounted systems as well as a line of carts, panel mounts, and orthodontic delivery system models.

1998-1999 Production methods are streamlined, products simplified for greater reliability. Methods for providing better service to customers were evaluated and field tested.

2000 Westar had outgrown the existing facility and moved to a larger state-of-the-art manufacturing facility, still located in Everett, Washington. This ultramodern factory is the newest and most modern facility available and its cost effectiveness reflects a continuing commitment to provide the best value to customers. Westar always keeps its hallmark slogan at the forefront of all it does.

2001 Westar developed and initiated production of the Westar 5000T Hydraulic chair, created and initiated production of the Nautica delivery system, with the innovative Micro-touch valve and ergonomic brake handle. Further improved manufacturing, customer service and cost controls are being put in place, and the factory has been modified to assure an easy transition to higher production rates without compromising quality, reliability and the rich appearance of Westar products.

Westar Mission Statement

The future could not be brighter for Westar. Our constant pursuit of the development of new technology and better products, our commitment to cost conscious pricing, stringent quality control, as well as excellent customer service, will allow Westar to supply products that meet all the needs of the most discriminating dental customer well into the future.

Westar Medical Products, Inc. is dedicated to becoming the leading supplier of world-class dental equipment by providing our customers with quality products delivered on time, every day. We are committed to excellence in everything we do through direct employee involvement, teamwork, and the continuous improvement of our products and services. In this way, we will ensure our future success, provide a rewarding work experience for our employee partners, and contribute superior products to the dental community.

Ruth E. Haller
President

Excursion Delivery Systems

Rotation around the toe of Westar chairs



5034 Flat Screen Monitor Mount
(monitor not included)

Westar Excursion Package

Shown in optional Silk Ultraleather Plush upholstery

Prices as shown above: Excursion with Nautica control, shown with 2001 Patient chair with internal umbilical, Excursion WeStarlight VIII. Options shown include Excursion Assistant package #5033 touchpad and plush upholstery (not included in prices below)

Price for package as shown above \$12,032 without stools.

Westar Excursion Package:	Electromechanical with Nautica	Electromechanical with Euro	Hydraulic with Nautica	Hydraulic with Euro
Model 5030 (Nautica) or 5037 (Euro)	\$4,264	\$4,777	\$4,264	\$4,777
Model 2001 Electromechanical patient chair	\$4,623	\$4,623		
Model 5000 Hydraulic patient chair			\$5,500	\$5,500
Excursion WeStarlight VIII (Part# 5032-245 includes pole and light)	\$1,318	\$1,318	\$1,318	\$1,318
D5000 Ultra Doctor Stool	\$574	\$574	\$574	\$574
A5000 Ultra Assistant Stool	\$769	\$769	\$769	\$769
Total	\$11,548	\$12,061	\$12,425	\$12,938

See page 35 for Dimensions and Specifications

STANDARD FEATURES	PART NO.	MODEL	5030	5037
<i>Suggested retail price</i>			\$4,264	
Excursion Delivery with Nautica Control				
Excursion Delivery with Euro Control				\$4,777
<u>Asepsis automatic control for three handpieces and syringe</u>			Nautica	Euro
Individual water coolant controls			✦	✦
Standard three-way syringe, with autoclavable tip - Asepsis style	4003-117		✦	
Standard three-way syringe, with autoclavable tip - Euro style	4003-294			✦
Asepsis flex arm with airlock	4000-430		✦	✦
Stainless steel tray and anti-skid pad	4003-013		✦	✦
Swivel tray and arm for Euro style delivery	4028			✦
Large contoured junction box with regulators and master shut offs	5024		✦	✦
Wet/dry foot control	4002-032		✦	✦
Master on/off	4003-099		✦	✦
Microtouch brake handle (Nautica only)			✦	
Purge system			✦	✦
Vortex valve with Lifetime warranty			✦	✦
Self-contained water system (bottle only, see below for city/bottle option)			✦	✦
Excursion chair mounting bracket, post and hardware (Front mount)	4000-169		✦	✦
FACTORY OPTIONS		PRICE		
MODEL 5033 - Assistant's utility option: High-volume evacuator, saliva ejector, syringe CV canister on rear arm	5033	\$915	✦	✦
Excursion flat screen monitor mount and arm (will need front mount if not purchased with unit)	5034	\$750	✦	✦
Front mount (needed for lights or monitors purchased without unit)	4000-169	\$270	✦	✦
Articulating keyboard for flat screen monitor mount	5043	\$370	✦	✦
Mouse pad tray for flat screen monitor mount	5044	\$60	✦	✦
Flat screen monitor mount with 2 inch pole clamp	5039-2IN	\$539	✦	✦
Excursion light post only (purchased with unit)	5032	\$468	✦	✦
Excursion light post only (not purchased with unit) includes front mount	5032-169	\$738	✦	✦
Swivel instrument tray holder for Nautica control	4000-013-1	\$162	✦	
Touchpad for all Westar chair functions including 5 programmable presets				
	Hydraulic chairs: Chair mounted	2000-230	✦	✦
	Delivery mounted	2000-233		
	Electro-mechanical chairs: Chair mounted	2000-231	✦	✦
	Delivery mounted	2000-234		
Upgrade to Plush upholstery with trim on chair and Ultraleather on Two stools (For details see page 32)	✦ 1006	\$538 \$324	✦	✦
2-way routing valve - city/bottle switch (must also purchase water MSO)	4003-061	\$22	✦	✦
Water MSO (for use with city/bottle routing valve)	4003-141	\$81	✦	✦
Additional handpiece control station	4000-050	\$162	✦	✦
Additional High volume evacuator with hose and asepsis holder	4000-051	\$78	✦	✦
Internal umbilical (for Westar chairs only)	4000-054-1	\$128	✦	✦
Handpiece intraoral illumination system (see page 29)			✦	✦
Belmont Bel-20 and Bel-50 Front Mount adapter	5040	\$540		
Belmont Bel-20 Assistant Package	5038	\$973		
Belmont Bel-50 Assistant Package	5036	\$915		

Nautica® 5000 Delivery Systems

Automatic control for three handpieces



Westar Nautica Package

Shown in optional Curry Ultra leather Plush upholstery

Prices as shown above: 5000 Nautica Cuspidor, shown with 2001 Patient chair, WeStarlight VIII, Ultra stools. Options shown include plush upholstery (not included in prices below) **Price for package as shown above \$12,412**

Westar Nautica Package:	Electromechanical with cuspidor	Electromechanical less cuspidor	Hydraulic with cuspidor	Hydraulic less cuspidor
Model 5000 or 5010	\$5,058	\$4,520	\$5,058	\$4,520
Model 2001 Electromechanical patient chair	\$4,623	\$4,623		
Model 5000 Hydraulic patient chair			\$5,500	\$5,500
WeStarlight VIII	\$850	\$850	\$850	\$850
D5000 Ultra Doctor Stool	\$574	\$574	\$574	\$574
A5000 Ultra Assistant Stool	\$769	\$769	\$769	\$769
Total	\$11,874	\$11,336	\$12,751	\$12,213

See page 35 for Dimensions and Specifications

STANDARD FEATURES	PART NO.	MODEL	5000	5010
<i>Suggested retail price</i> Nautica dental unit with contoured cuspidor and assistant 's instrumentation			\$5,058	
Nautica dental unit with assistant's instrumentation				\$4,520
<u>Asepsis automatic control for three handpieces and syringe</u>			With cuspidor	Less cuspidor
Individual water coolant controls			✧	✧
Standard three-way syringe, with autoclavable tip	4003-117		✧	✧
Westar arm with air brake and "S" shaped connection	4029		✧	✧
Stainless steel tray and swivel tray holder	4028 and 4003-013		✧	✧
Large contoured junction box with regulators and master shut offs	5024		✧	✧
Wet/dry foot control	4003-121		✧	✧
Purge system			✧	✧
Vortex valve with Lifetime warranty			✧	✧
<u>Post mount utility center</u>				
Contoured porcelain cuspidor on contoured vacuum box			✧	
Timed bowl rinse			✧	
Momentary cup filler			✧	
Telescoping arm with 2" pole clamp				✧
Autoclavable Premium High volume evacuator and hose			✧	✧
Autoclavable Premium Saliva ejector and hose			✧	✧
Self-contained water system (bottle only, see below for city/bottle option)			✧	✧
Water outlet on utility center - 1/4" quick disconnect			✧	✧
FACTORY OPTIONS		PRICE		
Additional handpiece control station	4000-050	\$162	✧	✧
Touchpad for all Westar chair functions including 5 programmable presets				
Hydraulic chairs: Chair mounted	2000-230		✧	✧
Delivery mounted	2000-233	\$374		
Electro-mechanical chairs: Chair mounted	2000-231		✧	✧
Delivery mounted	2000-234			
Upgrade to Plush upholstery with trim on chair and Ultraleather on Two stools (For details see page 32)	✧ 1006	\$538 \$324	✧	✧
2-way routing valve - city/bottle switch (must purchase water MSO for 5010)	4003-061	\$22	✧	✧
Water MSO (for use with city/bottle routing valve on 5010)	4003-141	\$81		✧
Remote cup fill and bowl flush, unit-mounted	4093-1	\$119	✧	
Additional High volume evacuator with hose and asepsis holder	4000-051	\$78	✧	✧
Additional standard syringe with tubing and asepsis holder (for assistant side)	4000-053	\$120	✧	✧
Additional Water/Air quick disconnect installed (1/4")	4091-6	\$33	✧	✧
Telescoping arm (in place of holder bar on cuspidor)	4027	\$270	✧	
Internal umbilical (for Westar chairs only)	4000-054-1	\$128	✧	✧
Additional umbilical per foot	4000-054	\$26	✧	✧
Handpiece intraoral illumination system (see page 29)			✧	✧
Delete chair-mount bracket when adapting to other chairs	2000-226	-\$190	✧	✧

Constellation Delivery System

Automatic control for three handpieces



Euro Control head



Westar Constellation Package

Shown in optional Curry Ultra leather Plush upholstery

Prices as shown above: 6000 Contoured Cuspidor, shown with 2001 Patient chair, WeStarlight VIII, Ultra stools *Options shown include touchpad and plush upholstery (not included in prices below)* **Price for package as shown above \$12,777**

Westar Constellation Package:	Electromechanical with cuspidor	Electromechanical less cuspidor	Hydraulic with cuspidor	Hydraulic less cuspidor
Model 6000 or 6010	\$4,725	\$4,175	\$4,725	\$4,175
Model 2001 Electromechanical patient chair	\$4,623	\$4,623		
Model 5000 Hydraulic patient chair			\$5,500	\$5,500
WeStarlight VIII	\$850	\$850	\$850	\$850
D5000 Ultra Doctor Stool			\$574	\$574
A5000 Ultra Assistant Stool			\$769	\$769
D2000E Economy Doctor Stool	\$354	\$354		
A2000E Economy Assistant Stool	\$593	\$593		
Total	\$11,145	\$10,595	\$12,418	\$11,868

See page 35 for Dimensions and Specifications

STANDARD FEATURES	PART NO.	MODEL	6000	6010	Euro 4035	Euro 4036
<i>Suggested retail price</i>						
Constellation dental unit with contoured cuspidor and assistant's instrumentation			\$4,725		\$5,376	
Constellation dental unit with assistant's instrumentation				\$4,175		\$4,946
<u>Deluxe or Euro automatic control for three handpieces and syringe</u>				With cuspidor	Less cuspidor	With cuspidor
				Less cuspidor		Less cuspidor
Standard three-way syringe, with autoclavable tip (Euro style on 4035 or 4036)	4003-117 (4003-294)		✧	✧	✧	✧
Westar arm with air brake and "S" shaped connection	4029		✧	✧	✧	✧
Stainless steel tray and anti-skid pad	4003-013		✧	✧	✧	✧
Large contoured junction box with regulators and master shut offs	5024		✧	✧	✧	✧
Standard foot control (Wet/dry on Euro)	4002-032 (4003-121)		✧	✧	✧	✧
Purge system			✧	✧	✧	✧
Vortex valve with Lifetime warranty			✧	✧	✧	✧
<u>Post mount utility center</u>						
Contoured porcelain cuspidor			✧		✧	
Timed bowl rinse			✧		✧	
Momentary cup filler			✧		✧	
Telescoping arm with 2" pole clamp				✧		✧
Autoclavable Premium High volume evacuator and hose			✧	✧	✧	✧
Autoclavable Premium Saliva ejector and hose			✧	✧	✧	✧
Self-contained water system (bottle only, see below for city/bottle option)			✧	✧	✧	✧
Water outlet on utility center - 1/4" quick disconnect			✧	✧	✧	✧
FACTORY OPTIONS			PRICE			
Additional handpiece control station	4000-050	\$162	✧	✧	✧	✧
Wet/dry foot control in lieu of standard	4003-121	\$69	✧	✧		
Swivel instrument tray holder	4000-013-1	\$162	✧	✧	✧	✧
Touchpad for all Westar chair functions including 5 programmable presets						
Hydraulic chairs: Chair mounted	2000-230	\$374	✧	✧	✧	✧
Delivery mounted	2000-233					
Electro-mechanical chairs: Chair mounted	2000-231		✧	✧	✧	✧
Delivery mounted	2000-234					
Upgrade to Plush upholstery with trim on chair and Ultraleather on Two stools (For details see page 32)	✧ 1006	\$538 \$324	✧	✧	✧	✧
2-way routing valve - city/bottle switch (must purchase water MSO for 6010)	4003-061	\$22	✧	✧	✧	✧
Water MSO (for use with city/bottle routing valve on 6010)	4003-141	\$81		✧		✧
Remote cup fill and bowl flush, unit-mounted	4093-1	\$119	✧		✧	
Additional High volume evacuator with hose and asepsis holder	4000-051	\$78	✧	✧	✧	✧
Additional standard syringe with tubing and asepsis holder (for assistant side)	4000-053	\$120	✧	✧	✧	✧
Additional Water/Air quick disconnect installed (1/4")	4091-6	\$33	✧	✧	✧	✧
Telescoping arm (in place of holder bar on cuspidor)	4027	\$270	✧		✧	
Internal umbilical (for Westar chairs only)	4000-054-1	\$128	✧	✧	✧	✧
Additional umbilical per foot	4000-054	\$26	✧	✧	✧	✧
Handpiece intraoral illumination system (see page 29)			✧	✧	✧	✧
Delete chair-mount bracket when adapting to other chairs	2000-226	-\$190	✧	✧	✧	✧

6000 Professional Delivery Systems

Automatic control for three handpieces



Westar Professional Package

Shown in optional Curry Ultraleather Plush upholstery

Prices as shown above: 6000 Professional Cuspidor, shown with 2001 Patient chair, WeStarlight VIII, Economy stools. Options shown include stainless instrument tray, 45" light pole, touchpad and plush upholstery (not included in prices below) **Price for package as shown above \$10,577**

Westar Professional Package:	Electromechanical with cuspidor	Electromechanical less cuspidor	Hydraulic with cuspidor	Hydraulic less cuspidor
Model 6000PC or 6000PA	\$2,620	\$2,335	\$2,620	\$2,335
Model 2001 Electromechanical patient chair	\$4,623	\$4,623		
Model 5000 Hydraulic patient chair			\$5,500	\$5,500
WeStarlight VIII	\$850	\$850	\$850	\$850
2" chair adaptor	\$250	\$250	\$250	\$250
D5000 Ultra Doctor Stool			\$574	\$574
A5000 Ultra Assistant Stool			\$769	\$769
D2000E Economy Doctor Stool	\$354	\$354		
A2000E Economy Assistant Stool	\$593	\$593		
Total	\$9,290	\$9,005	\$10,563	\$10,278

See page 35 for Dimensions and Specifications

STANDARD FEATURES	PART NO.	MODEL	6000PC	6000PA
<i>Suggested retail price</i> 6000PC dental unit with contoured cuspidor and assistant 's instrumentation			\$2,620	
6000PA dental unit with assistant's instrumentation				\$2,335
<i>Deluxe automatic control for three handpieces and syringe</i>			With cuspidor	Less cuspidor
Individual water coolant controls			✧	✧
Standard three-way syringe, with autoclavable tip	4003-117		✧	✧
Westar pole clamp flex arm without airlock (brake)	4029		✧	✧
Large contoured junction box with regulators and master shut offs	5024		✧	✧
Standard foot control	4002-032		✧	✧
Purge system			✧	✧
Vortex valve with Lifetime Warranty	4003-296		✧	✧
<i>Post mount utility center</i>				
Professional cuspidor with 8" Porcelain bowl	4003-134		✧	
Manual bowl rinse on/off			✧	
Manual cup fill			✧	
Telescoping arm				✧
Autoclavable Premium High volume evacuator and hose			✧	✧
Autoclavable Premium Saliva ejector and hose			✧	✧
2" Pole - 27" length (can be exchanged for 45" pole when mounting a light)			✧	✧
FACTORY OPTIONS		PRICE		
Westar Chair adaptor for 2" pole	2000-226	\$250	✧	✧
45" Pole in lieu of 27" pole	2000-214	N/C	✧	✧
Airlock (Brake) in flex arm	4000-435	\$100	✧	✧
Additional handpiece control station	4000-050	\$162	✧	✧
Wet/dry foot control in lieu of standard	4003-121	\$69	✧	✧
Touchpad for all Westar chair functions including 5 programmable presets				
Hydraulic chairs: Chair mounted	2000-230	\$374	✧	✧
Delivery mounted	2000-233			
Electro-mechanical chairs: Chair mounted	2000-231			
Delivery mounted	2000-234			
Upgrade to Plush upholstery with trim on chair and Ultraleather on Two stools (For details see page 32)	✧ 1006	\$538 \$324	✧	✧
Self contained water bottle	4003-193-1	\$162	✧	✧
City/Bottle water system	4095-4	\$204	✧	✧
Timed Bowl flush	4093	\$103	✧	
Additional High volume evacuator with hose and asepsis holder	4000-051	\$78	✧	✧
Additional standard syringe with tubing and asepsis holder (for assistant side)	4000-053	\$120	✧	✧
Water/Air quick disconnect installed (1/4")	4091-6	\$33	✧	✧
Telescoping arm (in place of holder bar on cuspidor)	4027	\$270	✧	
Internal umbilical (for Westar chairs only)	4000-054-1	\$128	✧	✧
Stainless instrument tray with anti-skid pad	4003-102	\$51	✧	✧
Plastic instrument tray with anti-skid pad	4003-237	\$12	✧	✧
Additional umbilical per foot	4000-054	\$26	✧	✧
Handpiece intraoral illumination system (see page 29)			✧	✧

5000 Hydraulic Patient Chair



Shown in optional Diplomat Blue Ultraleather Plush Upholstery

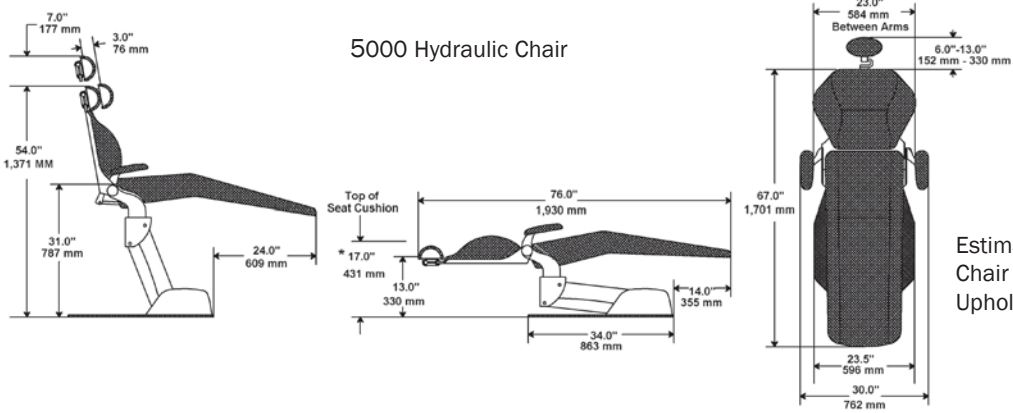

Estimated shipping dimensions and weights
 Chair - 41L x 31W x 28H 330 lbs. plus
 Upholstery - 47L x 11W x 23H 30 lbs.

Factory Options for Patient Chairs



Standard headrest
7000-028 \$429



Ponytail headrest
7000-609 \$529



Florintine Burl Trim
2000-229 \$215/set



Touchpad
delivery mounted
Hydraulic 2000-233
Electromechanical 2000-234



Touchpad
chair mounted
2000-230
2000-231

\$374



Sling upholstery



Asepsis upholstery Shown with optional covered arms

STANDARD FEATURES	PART NO.	MODEL	5000-001T	5000-001S	5000-001SA	5000-001
<i>Suggested Retail Price</i> 5000 Plush with trim hydraulic patient chair			\$6,038			
5000 Slings Plush with trim hydraulic patient chair				\$6,038		
5000 Slings asepsis hydraulic patient chair					\$5,602	
5000 Asepsis hydraulic patient chair						\$5,500
Foot Control with two programmable preset positions and two automatic exit positions (return), 7 function			❖	❖	❖	❖
Hydraulic Cantilever system			❖	❖	❖	❖
All-metal construction with HiGlos powdercoat inside and out			❖	❖	❖	❖
Safety shut-off base plate			❖	❖	❖	❖
Low voltage			❖	❖	❖	❖
Thermal overload protection			❖	❖	❖	❖
Left/Right patient access with arms that swing up			❖	❖	❖	❖
Locking swivel, 60 degree			❖	❖	❖	❖
Double-articulating headrest <i>adjustable for height and wheelchair positioning</i>			❖	❖	❖	❖
Synchronized seat and back tilt			❖	❖	❖	❖
Quick change upholstery (Plush style done in Ultraleather only)			❖	❖	❖	❖
Upholstered arms			❖	❖	❖	
Three year warranty			❖	❖	❖	❖
FACTORY OPTIONS	PART NO.	PRICE				
Chair mount adapter	2000-226	\$250	❖	❖	❖	❖
Arm covers for Asepsis 5000-001	7000-096-1	\$95/set				❖
Touchpad with 5 programmable presets and two automatic exit (return) Chair mounted Delivery mounted	2000-230 2000-233	\$374	❖	❖	❖	❖
Non-articulating headrest (can be purchased or in lieu of articulating)	7000-028	\$429	❖	❖	❖	❖
Ponytail headrest (\$100 if purchased or in lieu of articulating)	7000-609	\$529	❖	❖	❖	❖
Replacement Double articulating headrest with upholstery	7000-021	\$429	❖	❖	❖	❖
Replacement upholstery, Plush with trim	7005-703	\$1,438	❖	❖	❖	❖
Replacement upholstery, Sling plush with trim	7005-706	\$1,438		❖		
Replacement upholstery, Sling asepsis	7005-709	\$1,000			❖	
Replacement upholstery, asepsis (slide on back)	7005-700	\$900				❖
Replacement headrest upholstery	7005-041	\$80	❖	❖	❖	❖
Ultraleather upgrade (not plush styling)	1005	\$404			❖	❖
Florentine Burl Trim	2000-229	\$215/set	❖	❖	❖	❖
Extended Three Year Warranty for each chair	1008	\$400	❖	❖	❖	❖

Electromechanical Patient Chairs



Shown in optional Curry
Ultraleather Plush Upholstery

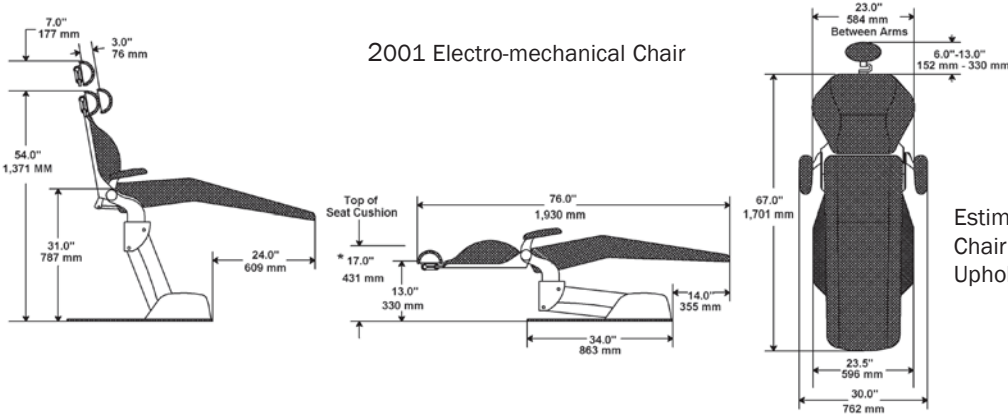

Estimated shipping dimensions and weights
 Chair - 41L x 31W x 28H 300 lbs. plus
 Upholstery - 47L x 11W x 23H 30 lbs.



Shown in optional Silk
Ultraleather Plush Upholstery

STANDARD FEATURES	PART NO.	MODEL	2000-401T	2000-401S	2000-401SA	2000-401	2000-017
<i>Suggested Retail Price</i> 2001 Plush with trim electromechanical patient chair (available in ultraleather only)			\$5,161				
2001 Slings Plush with trim electromechanical patient chair (available in ultraleather only)				\$5,161			
2001 Slings asepsis electromechanical patient chair					\$4,725		
2001 Asepsis electromechanical patient chair						\$4,623	
2001E Economy Asepsis electromechanical patient chair							\$4,299
Foot Control with two programmable preset positions and automatic exit (return), 7 function			❖	❖	❖	❖	
Foot Control with automatic return, 5 function							❖
Electromechanical Cantilever system			❖	❖	❖	❖	❖
All-metal construction with HiGlos powdercoat inside and out			❖	❖	❖	❖	❖
Thermal overload protection			❖	❖	❖	❖	❖
Left/Right patient access with arms that swing up			❖	❖	❖	❖	
Stationary armrests							❖
Locking swivel, 60 degree			❖	❖	❖	❖	
Double-articulating headrest <i>adjustable for height and wheelchair positioning</i>			❖	❖	❖	❖	❖
Synchronized seat and back tilt			❖	❖	❖	❖	❖
Quick change upholstery (Plush style done in Ultraleather only)			❖	❖	❖	❖	❖
Upholstered arms			❖	❖	❖		
Three year warranty			❖	❖	❖	❖	❖
FACTORY OPTIONS	PART NO.	PRICE					
Chair mount adapter	2000-226	\$250	❖	❖	❖	❖	❖
Arm covers for Asepsis 2001 and 2001E	7000-096-1	\$95/set				❖	❖
Touchpad with 5 programmable presets and two automatic exit (return) Chair mounted Delivery mounted	2000-231 2000-234	\$374	❖	❖	❖	❖	
Non-articulating headrest (can be purchased or in lieu of articulating)	7000-028	\$429	❖	❖	❖	❖	❖
Ponytail headrest (\$100 if purchased or in lieu of articulating)	7000-609	\$529	❖	❖	❖	❖	❖
Replacement Double articulating headrest with upholstery	7000-021	\$429	❖	❖	❖	❖	❖
Replacement upholstery, Plush with trim (available in ultraleather only)	7005-703	\$1,438	❖				
Replacement upholstery, Sling plush with trim (available in ultraleather only)	7005-706	\$1,438		❖			
Replacement upholstery, Sling asepsis	7005-709	\$1,000			❖		❖
Replacement upholstery, asepsis (slide on back)	7005-700	\$900				❖	❖
Replacement headrest upholstery	7005-041	\$80	❖	❖	❖	❖	❖
Ultraleather upgrade (not plush styling)	1005	\$404	❖	❖	❖	❖	❖
Florentine Burl Trim	2000-229	\$215/set	❖	❖	❖	❖	❖
Extended Three Year Warranty for each chair	1008	\$400	❖	❖	❖	❖	❖

OSIII Oral Surgery Patient Chair



Shown with Eight way I. V. arm option

Shown in Duration Taupe Upholstery

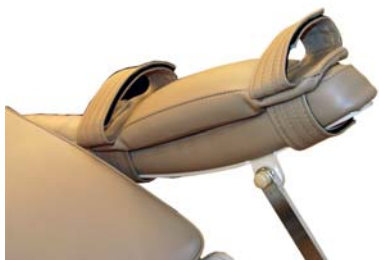

Standard I. V. arm pillow
Interchangeable Left and Right



Eight way articulating I. V. arm
option
Interchangeable Left and Right



Chinner headrest option

STANDARD FEATURES	PART NO.	MODEL	2000-080-2
<i>Suggested Retail Price</i> OSIII Oral surgery electromechanical patient chair			\$6,242
Foot Control with two programmable preset positions and automatic exit (return), 7 function			❖
Electromechanical Cantilever system			❖
All-metal construction with HiGlos powdercoat inside and out			❖
Thermal overload protection			❖
Left/Right I. V. arms with one interchangeable pillow			❖
Double-articulating headrest with lock down for surgery feature <i>adjustable for height and wheelchair positioning</i>			❖
Synchronized seat and back tilt			❖
Quick change upholstery			❖
Upholstered arms			❖
Three year warranty			❖
FACTORY OPTIONS	PART NO.	PRICE	
Touchpad with 5 programmable presets and two automatic exit (return)			
Chair mounted	2000-231	\$374	❖
Delivery mounted	2000-234		
Chinner double articulating headrest (can be purchased as upgrade for \$308)	7000-608	\$737	❖
Eight way articulating I. V. arm	2000-220	\$586	❖
Leg and Body strap (color: black only)	2000-223	\$164	❖
Additional I. V. pillow only	7000-116	\$162	❖
Height spacer 3" (factory installed only)	2000-119	\$205	❖
Mobile locking base	7000-371	\$1,251	❖
Chair mount adapter	2000-226	\$250	❖
Replacement Double articulating headrest with upholstery	7000-021	\$429	❖
Replacement upholstery asepsis	7000-535	\$1,238	❖
Replacement headrest upholstery	7005-041	\$80	❖
Ultraleather upgrade (not plush styling)	1005	\$404	❖
Extended Three Year Warranty for each chair	1008	\$400	❖

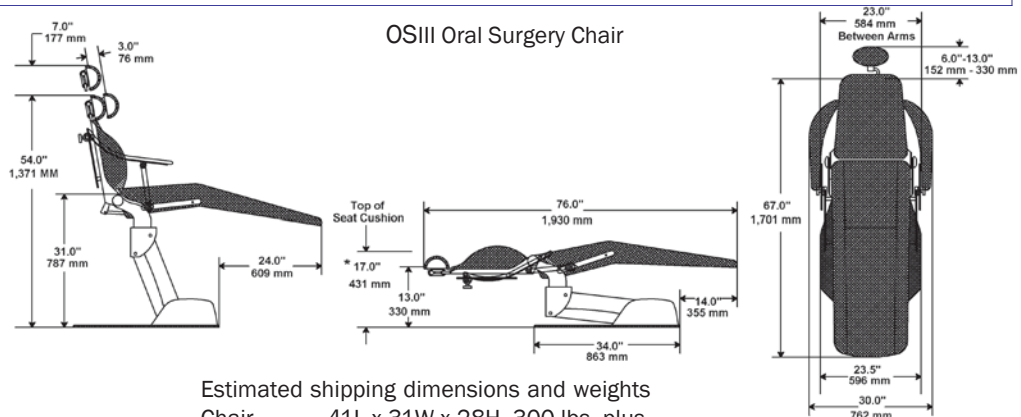

Estimated shipping dimensions and weights
 Chair - 41L x 31W x 28H 300 lbs. plus
 Upholstery - 47L x 11W x 23H 30 lbs.

2005 Orthodontic Patient Chair



Panel Mount 4062 for two handpiece manual
 SP400FB Ortho cabinet with keyboard drawer in fixed base
 FPMA103G Panel mount arm (grey) (monitor not included)
 D5000 Ultra doctor's stool in optional Papyrus Ultraleather
 2005 shown in optional Papyrus Ultraleather Plush upholstery



Panel Mount 4062 for two handpiece manual
 SP200CA Ortho standard mobile cabinet on caster base
 D5000 Ultra doctor's stool in optional Papyrus Ultraleather
 2005 shown in optional Papyrus Ultraleather Plush upholstery

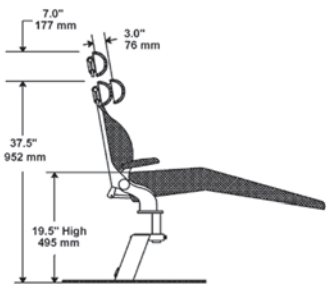

2005 Orthodontic Chair with
 Electro-mechanical backrest

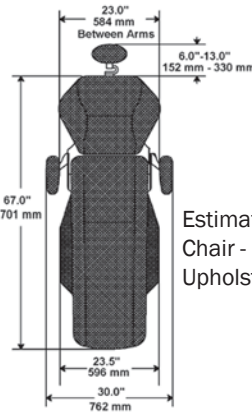
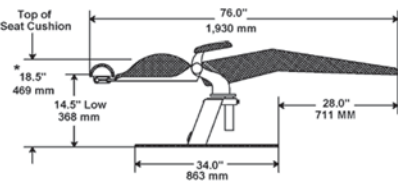

Estimated shipping dimensions and weights
 Chair - 41L x 31W x 28H 240 lbs. plus
 Upholstery - 47L x 11W x 23H 30 lbs.

STANDARD FEATURES	PART NO.	MODEL	2000064T	2000-064S	2000-064SA	2000-064
<i>Suggested Retail Price</i> 2005 Plush with trim Orthodontic patient chair (available in ultraleather only)			\$3,607			
2005 Slings Plush with trim Orthodontic patient chair (available in ultraleather only)				\$3,607		
2005 Slings asepsis Orthodontic patient chair					\$3,171	
2005 Asepsis Orthodontic patient chair						\$3,069
Foot Switches with automatic exit (return), mounted on pedestal			❖	❖	❖	❖
Electromechanical backrest			❖	❖	❖	❖
All-metal construction with HiGlos powdercoat inside and out			❖	❖	❖	❖
Pedestal base with 5" of manual height adjustment			❖	❖	❖	❖
Double-articulating headrest <i>adjustable for height and wheelchair positioning</i>			❖	❖	❖	❖
Synchronized seat and back tilt			❖	❖	❖	❖
Quick change upholstery (Plush style done in Ultraleather only)			❖	❖	❖	❖
Three year warranty			❖	❖	❖	❖
FACTORY OPTIONS	PART NO.	PRICE				
Accessory power cord	2000-238	\$144	❖	❖	❖	❖
Chair mount adapter	2000-226	\$250	❖	❖	❖	❖
Stationary arms	2000-243	\$200	❖	❖	❖	❖
Moveable arms (arms swing up)	2000-244	\$355	❖	❖	❖	❖
Arm covers for Asepsis 2005 with added arm feature	7000-096-1	\$95/set				❖
Touchpad with 5 programmable presets and two automatic exit (return) must also purchase Preset circuit board (see below)						
Chair mounted	2000-231	\$374	❖	❖	❖	❖
Preset circuit board (one preset will work with the pedestal switches, must purchase foot control or touchpad to work more than one preset)	7003-150-2A	\$300	❖	❖	❖	❖
Foot Control - 7 function	7000-060-2	\$350	❖	❖	❖	❖
Non-articulating headrest (can be purchased or in lieu of articulating)	7000-028	\$429	❖	❖	❖	❖
Ponytail headrest (\$100 if purchased in lieu of articulating)	7000-609	\$529	❖	❖	❖	❖
Replacement Double articulating headrest with upholstery	7000-021	\$429	❖	❖	❖	❖
Replacement upholstery, Plush with trim (available in ultraleather only)	7005-703	\$1,438	❖			
Replacement upholstery, Sling plush with trim (available in ultraleather only)	7005-706	\$1,438		❖		
Replacement upholstery, Sling asepsis	7005-709	\$1,000			❖	
Replacement upholstery, asepsis (slide on back)	7005-700	\$900				❖
Replacement headrest upholstery	7005-041	\$80	❖	❖	❖	❖
Ultraleather upgrade (not plush styling)	1005	\$404	❖	❖	❖	❖
Florentine Burl Trim	2000-229	\$215/set	❖	❖	❖	❖
Extended Three Year Warranty for each chair	1008	\$400	❖	❖	❖	❖

ORTHO CARTS STANDARD FEATURES	PART NO .	MODEL	SP200FB	SP200CA	SP400FB	SP400CA
Standard Ortho cart with fixed base			\$2,198			
Standard Ortho cart with mobile base			\$2,198			
Ortho cart for CPU with fixed base			\$2,625			
Ortho cart for CPU with mobile base			\$2,625			
Four drawer Module, two shallow drawers and two deep drawers			❖	❖		
Four drawer Module, three shallow drawers and one deep drawer					❖	❖
Rear access door			❖	❖		
Access door for CPU on side					❖	❖
Keyboard pullout					❖	❖
Laminated top and sides			❖	❖	❖	❖
Duplex outlet			❖	❖	❖	❖
Choice of Laminated colors			❖	❖	❖	❖
FACTORY OPTIONS	PART NO .	PRICE				
Solid surface top for standard ortho cart	DCSP200	\$1,311	❖	❖		
Solid surface top for CPU ortho cart	DCSP400	\$1,524			❖	❖
Flat panel monitor mount (monitor not included)	FPM A103G	\$360			❖	❖
PANEL MOUNT DELIVERY SYSTEMS AVAILABLE FOR ALL ORTHO CARTS	PART NO .	PRICE				
Panel mount One handpiece manual includes one 4" hangerbar	4061	\$694	❖	❖	❖	❖
Panel mount Two handpiece manual includes one 4" hangerbar	4062	\$856	❖	❖	❖	❖
Panel mount Three handpiece automatic includes one 8" hangerbar	4063	\$1,480	❖	❖	❖	❖
Three way syringe with autoclavable tip						
Standard foot control						
Junction box accessories (no box) Air/Water shut off valves, regulators and filters, Water MISO valve						
Remote mounted hangerbar (non-swivel)						
Legendary Vortex valve (Guaranteed for life) available on 4063 only						
FACTORY OPTIONS FOR PANEL MOUNT UNITS	PART NO .	PRICE	4061	4062	4063	
Vacuum Package (HVE, SE)	4091-7	\$185	❖	❖	❖	
Vacuum Package (HVE, SE, Syringe)	4091	\$302	❖	❖	❖	
Panel mount Clean water bottle (bottle water only)	4003-193-1	\$162	❖	❖	❖	
Panel mount Clean water system (city/bottle switch)	4095-4	\$204	❖	❖	❖	
Swivel remote hangerbar	4064	\$133	❖	❖	❖	
4" hangerbar	4003-276	\$31	❖	❖	❖	
8" hangerbar	4003-275	\$46	❖	❖	❖	
8" hangerbar in lieu of 4" on 4061 or 4062 upcharge	4003-275	\$15	❖	❖		
Junction box with lid (no accessories)	5025-1	\$125	❖	❖	❖	



SP200 Standard Ortho Cart
Height 31"
Estimated shipping weight 250 lbs

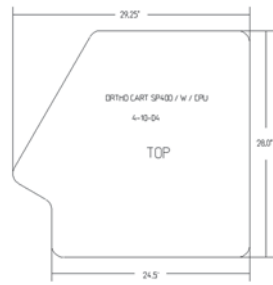
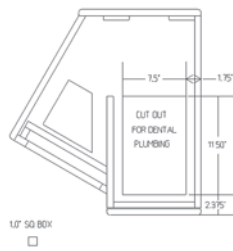

SP400 CPU Ortho Cart
Height 34"
Estimated shipping weight 250 lbs

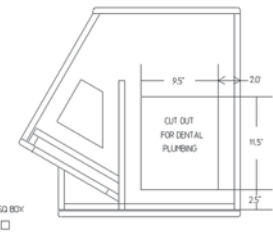

Panel Mount Delivery Systems



4061
One handpiece
manual



4062
Two handpiece
manual



4063
Three
handpiece
automatic



Remote flush mounted
hanger bar (non-swivel)
4" for 4061 and 4062 and
8" for 4063

Estimated shipping dimensions and weights:
Panel Mount - 20L x 8W x 8H 15 lbs.

Optional feature: 4064 Swivel
hanger bar (shown with holders, syringe
and handpiece connectors sold separately)



Miscellaneous Unit Parts

4035-1 Euro Control head ❖ 5010-1 Control head ❖ 6010-1 Control head ❖ 4020-1 Control head ❖ 4076-1 Control
Three handpiece automatic Three handpiece auto Three handpiece auto Three handpiece auto Two handpiece auto
Suggested Retail: \$1988 \$1,888 \$1,669 \$1,050 \$641
Order# 4035-1 5010-1 6010-1 4020-1 4076-1



4035-1

Shown with optional touch pad



6010-1



4076-1

Standard Features:

- Legendary Vortex® valve (Guaranteed for life)
- Individual water coolant adjustment
- Three way syringe with autoclavable tip
- Non-retracting water coolant
- Asepsis Midwest 4 hole tubing
- Standard foot control

Optional Features:

- | | | |
|--|----------|-------|
| 1/2" umbilical per foot | 4000-055 | \$19 |
| Junction box with lid (no accessories) | 5025-1 | \$125 |
| Utility Center accessories (no box) | 4024-0 | \$248 |
| Stainless instrument tray | 4003-102 | \$51 |
| Plastic instrument tray | 4003-237 | \$12 |



5010-1



4020-1

Estimated shipping dimensions and weights:
Control head - 20L x 20W x 7H 15 lbs.

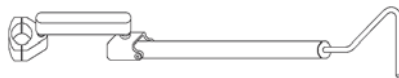

Optional Vacuum Kit	Optional Vacuum Kit with Syringe
❖ 2 Standard Grey Holders	❖ 3 Standard Grey Holders
❖ HVE and SE, 5' tubing	❖ HVE and SE, and Syringe 5' tubing
❖ CV Canister	❖ CV Canister
❖ 1/2" Spiral Flex, 9'	❖ 1/2" Spiral Flex, 9'
Retail Price: \$185	Retail Price: \$302
Order# 4091-7	Order# 4091

4026E Cuspidor Package
\$1,614 without bottle



4027 Telescoping arm
\$270 arm only

4023E Assistant Package
\$901 without bottle

Cabinet Mount Delivery Systems

Nautica® 5000-3 Cabinet Mount ❖ 4020-3 Cabinet Mount ❖ 4020-4 Rear Slide ❖ 4020 Control with Flex Arm

<i>Suggested Retail:</i>	\$3,336	\$2,798	\$1,614
<i>Order#</i>	5000-3	4020-3	4020-4
<i>Standard Features:</i>			

5000-3 Delivery System:

- Legendary Vortex® valve (Guaranteed for life)
- Oil collection system with hepa filter
- Flex arm with Microtouch® brake handle
- Clean water system (bottle water only)
- Individual water coolant adjustment
- Three way syringe with autoclavable tip
- Handpiece purge toggle
- Asepsis Midwest 4 hole tubing
- Wet/dry foot control
- Utility Center accessories (no box)
- Electronics cable pre-wiring
- Instrument tray (Stainless) with non-skid pad
- 2" diameter cabinet/wall mount bracket



Estimated shipping dimensions and weights:
Control Head - 31L x 16W x 9H
42 lbs.

Standard Features:

4020-3 Delivery System:

- Legendary Vortex® valve (Guaranteed for life)
- Flex arm with pneumatic brake
- Individual water coolant adjustment
- Three way syringe with autoclavable tip
- Non-retracting water coolant
- Asepsis Midwest 4 hole tubing
- Standard foot control
- Utility Center accessories (no box)
- Electronics cable pre-wiring
- Instrument tray (plastic) with non-skid pad
- 2" diameter cabinet/wall mount bracket



Estimated shipping dimensions and weights:
Control Head - 31L x 16W x 9H
42 lbs.

Standard Features:

4020-4 Delivery System:

- Legendary Vortex® valve (Guaranteed for life)
- Rear slide cabinet mount box
- Individual water coolant adjustment
- Three way syringe with autoclavable tip
- Asepsis Midwest 4 hole tubing
- Standard foot control
- Utility Center accessories (no box)
- Instrument tray (plastic) with non-skid pad
- 7' umbilical (1/2")



Estimated shipping dimensions and weights:
Control Head - 31L x 16W x 9H
42 lbs.

Standard Features:

4020 Delivery System:

- Legendary Vortex® valve (Guaranteed for life)
- Flex arm with pneumatic brake
- Individual water coolant adjustment
- Three way syringe with autoclavable tip
- Non-retracting water coolant
- Asepsis Midwest 4 hole tubing
- Standard foot control
- Electronics cable pre-wiring (2 conductor)
- Instrument tray (plastic) with non-skid pad



Estimated shipping dimensions and weights:
Control Head - 31L x 16W x 9H 42 lbs.

Optional Features:

Additional umbilical per foot (1/2")	4000-055	\$19	
Contoured Junction box with lid (no access.)	5025-1	\$125	
Contoured Utility Center with accessories	5024	\$373	
Instrumentation	4091-7	\$185	

collector, HVE, SE, 2 holders, 1/2" spiralflex

Westar Medical Products, Inc. ❖ Phone: 800/499-3945 ❖ Fax: 425/356-2961

Miscellaneous Controls

4023-5 Assistant ❖	4026-1 Pole Mount Cuspidor ❖	4069 Duo 12 O'Clock ❖	Wall Mount Duo Power Arm
<i>Suggested Retail:</i> \$769	\$848	\$2,163	\$4,843
<i>Order#</i> 4023-5	4026-1	4069	4066

Standard Features:

4023-5 Assistant Package:

- Pivoting arm mounted CV
- Removable screen (trap)
- HVE with autoclavable valve
- SE with autoclavable valve
- Three way syringe with autoclavable tip
- Clean water bottle (bottle water only)



Estimated shipping dimensions and weights:
Assistant - 20L x 8W x 8H
5 lbs.

Standard Features:

4026-1 Pole mount cuspidor:

- 7' umbilical
 - Push button bowl flush and cup fill
 - 8" porcelain bowl
- Optional Features:
- Timed bowl flush 4093 \$103
 - Vacuum Package 4091-5 \$210 includes hanger bar, solids collector, HVE, SE, 2 holders, 1/2" spiralflex



Estimated shipping dimensions and weights:
Cuspidor - 24L x 22W x 12H
24 lbs.

Standard Features:

4069 Duo 12 O'clock Cabinet mount:

- Three handpiece automatic with Legendary Vortex® valve (Guaranteed for life)
- Individual water coolant adjustment
- Three way syringe with autoclavable tip (DR's side)
- Wet/Dry foot control
- Self-contained water system
- HEPA filtration for handpiece oil collection
- HVE and SE with autoclavable valve



Estimated shipping dimensions and weights:
12 O'Clock separately - 29L x 17W x 12H 26 lbs
Cabinet - 48L x 44W x 63H 475 lbs.

Optional Features:

- 12 O'clock Assistant only 4065 \$761 (Cabinet sold separately 4088)
- Dimensions: 24D x 44W x 76H

Standard Features:

Wall mount Duo power arm Delivery System:

- Legendary Vortex® valve (Guaranteed for life)
- Power arm with pneumatic brake
- Individual water coolant adjustment
- Three way syringe with autoclavable tip
- Non-retracting water coolant
- Asepsis Midwest 4 hole tubing
- Standard foot control
- Electronics cable pre-wiring
- Assistant arm with Solids collector
- HVE and SE with autoclavable valve
- Water Quick Disconnect
- Duplex outlet
- Clean water bottle
- 19" x 22" Laminate Top

Optional Features:

- Wall mount Assistant only power arm 4068 \$3,229
- Power Arm only 4000-188 \$2035
- Additional 1 1/4" umbilical per foot 4000-059 \$19
- Contoured Junction box (no access.) 5025-1 \$125
- Contoured Junction box w/ access. 5024 \$373
- Storage organizer (four bins) 4003-236 \$226
- (three bins) 4003-255 \$189
- (two bins) 4003-291 \$205



Estimated shipping dimensions and weights:
Duo - 29L x 17W x 12H 26 lbs

Cart Delivery Systems



- 4081 Dual purpose cart
- 4082 Assistant's cart (*less the control head*)

Estimated shipping dimensions and weights:

- 4081 - 22L x 22W x 30H 63 lbs
- 4082 - 22L x 22W x 30H 40 lbs



- 4085 Doctor's Cart
- 4089 Doctor's and Assistant Cart

Estimated shipping dimensions and weights:

- 4085 - 22L x 22W x 30H 51 lbs
- 4089 - 22L x 22W x 30H 55 lbs

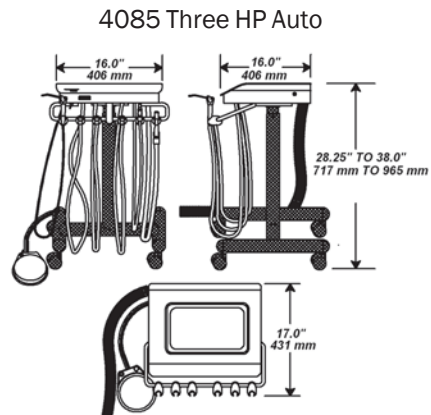
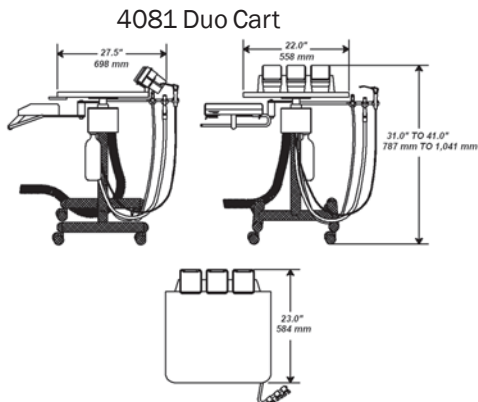

STANDARD FEATURES	PART NO.	MODEL	4081	4082	4085	4089
Suggested Retail Price						
Dual purpose cart style delivery system			\$3,280			
Assistant's cart style delivery system				\$2,153		
Doctor's cart style delivery system					\$2,768	
Doctor's and assistant's cart style delivery system						\$2,953
Swing mount delivery for left/right convertibility			❖	❖		
Legendary Vortex valve with Lifetime warranty			❖		❖	❖
19" x 22" laminated surface - Surf White	4003-290		❖	❖		
Electrical outlet, AC			❖	❖		
Autocavable Premium High Volume Evacuator and hose	4003-008		❖	❖		❖
Autocavable Premium Saliva Ejector and hose	4003-009		❖	❖		❖
Standard three-way syringe with autoclavable tip	4003-117		❖		❖	❖
Assistant's standard syringe with autoclavable tip	4000-053		❖	❖		
Contoured junction box with regulators and master shut offs	5024		❖		❖	❖
Master on/off	4003-099		❖		❖	❖
Three handpiece automatic control			❖		❖	❖
Adjustable coolant air and water for each handpiece			❖		❖	❖
Standard foot control	4002-032		❖		❖	❖
Purge system			❖		❖	❖
Stainless steel tray with anti-skid pad	4003-102		❖		❖	❖
Water/air quick disconnect (1/4")	4091-6	\$33	❖			
Self-contained water system (bottle only, see below for city/bottle option)			❖	❖	❖	❖
FACTORY OPTIONS	PART NO.	PRICE				
Additional HVE, hose and holder	4000-051	\$78	❖	❖	❖	❖
Wet/dry foot control in lieu of standard	4003-121	\$69	❖		❖	❖
City/bottle upgrade (includes water MSO and routing valve)	4095-7	\$179	❖	❖	❖	❖
Swivel instrument tray holder	4000-013-1	\$162	❖	❖	❖	❖
Foot control rest	4000-241	\$154	❖		❖	❖
Storage organizers (3 bin)	4003-236	\$226	❖	❖	❖	❖
Storage organizers (4 bin)	4003-255	\$189	❖	❖	❖	❖
Storage bin (1 bin)	4003-256	\$26	❖	❖	❖	❖
Additional umbilical per foot (1 1/4")	4000-059	\$19	❖	❖		
Additional umbilical per foot (4085 and 4089 carts)	4000-060	\$19			❖	❖
Handpiece intraoral illumination system (see page 29)			❖		❖	❖
Cart H-frame	4080	\$493				
Cart top laminated (19" x 22") Surf White	4003-290	\$214				
Cart top laminated (14" x 14") Surf White	4003-291	\$205				
Touchpad for all Westar chair function (5 programmable presets) with 10' extension	4002-242-0					
Electro-mechanical chairs: Chair mounted	2000-230		❖	❖	❖	❖
Delivery mounted	2000-233	\$534				
Hydraulic chairs: Chair mounted	2000-231		❖	❖	❖	❖
Delivery mounted	2000-234					

WeStarlight Operator Lighting



STANDARD FEATURES	MODEL	PRICE
W eStarlight VIII Chair mounted operator light	2000-245	\$850
W eStarlight VIII Wall mounted operator light	2000-235	\$1,281
W eStarlight V Ceiling mounted operator light	2000-225	\$2,147
WeStarlights available in 120 volt or 220 volt (please specify)		
Dual Intensity color temperature: 4500 to 5500 degrees kelvin	❖	
Light pattern: 3.25" x 6.5"	❖	
Bulb: Quartz halogen 12v 60w	❖	
Scratch and discoloration resistant shield	❖	
Shadow free	❖	
FACTORY OPTIONS FOR W eSTARLIGHT	PART NO.	PRICE
Chair mount adapter	2000-226	\$250
45" Light pole - powdercoated light beige	2000-214	\$108
1.375 I.D. pole adapter (for W eStarlight VIII)	4002-071	\$23
1.71 I.D. pole adapter (for W eStarlight III)	7002-235	\$23
Replacement reflector	4003-358	\$439
Replacement bulb	4003-340	\$31
Replacement shield	4003-336	\$144
Replacement transformer - 120 volt 60 hz	4003-397	\$230

Intraoral Handpiece Illumination Systems

SYSTEM	PART NO.	PRICE	INSTALLED
Complete Non-variable One handpiece ISO-B, 5-pin System with Handpiece tubing (120v) Includes: non-variable illumination system, One ISO-B handpiece tubing (sand) Lamp module for 5-hole handpiece tubing	123215HP 1232REK 1241RSD 1242	\$420	\$502
Complete Non-variable One handpiece ISO-B, 6-pin System with Handpiece tubing (120v) Includes: non-variable illumination system, One ISO-B handpiece tubing (sand)	12321HP 1232REK 1240RSD	\$360	\$442
Features ❖ Fits any 5-hole or ISO-C (6 pin) handpiece ❖ Voltage regulated ❖ Each tubing independantly adjustable ❖ One handpiece tubing ❖ Brilliant long-life Krypton lamp ❖ Automatic activation by drive air ❖ Non-variable power pack for increased bulb life			
Complete Variable up to Three handpiece ISO-B, 5-pin System with One Handpiece tubing (120v) Includes: Variable illumination system, One ISO-B handpiece tubing (sand) Lamp module for 5-hole handpiece tubing	123235HP 1232R3V 1241RSD 1242	\$702	\$784
Complete Variable up to Three handpiece ISO-B, 6-pin System with One Handpiece tubing (120v) Includes: Variable illumination system, One ISO-B handpiece tubing (sand)	12323HP 1232R3V 1240RSD	\$642	\$724
Features ❖ Fits any 5-hole or ISO-C (6 pin) handpiece ❖ Voltage regulated ❖ Each tubing independantly adjustable ❖ Up to three handpiece tubings ❖ Brilliant long-life Krypton lamp ❖ Automatic activation by drive air ❖ Variable power pack for increased bulb life			
FACTORY OPTIONS			
Non-variable one handpiece illumination system power supply (120v) Includes: non-variable power pack and 120volt transformer	1232REK	\$200	\$244
Variable illumination system power supply (120v) Includes: variable power pack and 120 volt transformer	1232R3V	\$482	\$526
Special one handpiece control for 4069 Duo 12 O'clock, or for Power Arm style delivery Includes: Variable ISO-B illumination system One ISO-B handpiece tubing (sand) - 120" long Lamp module for 5 hole handpiece tubing	1232R2V 9SLG120 1242	\$460	\$542
ISO-B, 5-hole handpiece tubing, straight, sand (bulb not included) 5-hole tubings connect to any ISO-B 5-hole handpiece using #1242 lamp module	1232RSD	\$160	\$195
Lamp Module for all 5-hole handpiece tubings High intensity Krypton-halogen lamp, 80 hour life, mounts directly behind handpiece	1242	\$60	
ISO-C handpiece tubing, straight, sand (6-pin) ISO-C tubings connect directly to any 6-pin ISO-C handpiece. Lamp supplied within handpiece.	1240RSD	\$160	\$195
<i>Note: Westar does not warranty system lamps. The purchase of a spare bulb is recommended.</i>			

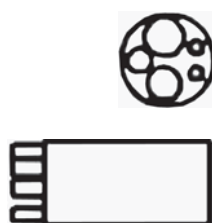
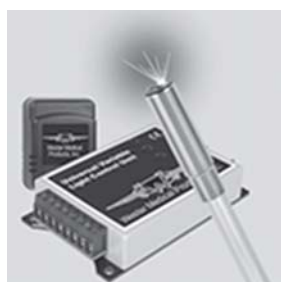

5-hole lamp module



ISO-C 6 pin connection

5000 Ultra Operator Seating



D5000



A5000



Estimated shipping dimensions and weights:

D5000 - UPS: 22L x 22W x 16H LTL: 22L x 22W x 30H 26 lbs

A5000 - UPS: 22L x 22W x 30H LTL: 22L x 22W x 30H 39 lbs

2000 Economy Operator Seating



D2000E



A2000E

Estimated shipping dimensions and weights:

D2000E - UPS: 22L x 22W x 16H LTL: 22L x 22W x 30H 25 lbs

A2000E - UPS: 22L x 22W x 30H LTL: 22L x 22W x 30H 31 lbs

STANDARD FEATURES	PART NO.	MODEL	D5000	A5000	D2000E	A2000E
Ultra doctor's stool with contoured seat	2000-104-1		\$574			
Ultra assistant's stool with 16" round seat	2000-105-1			\$769		
Economy doctor's stool	2000-103-1				\$354	
Economy assistant stool	2000-102-1					\$593
Ultra doctor's stool with 16" round seat	2000-104-3		\$574			
Ultra assistant's stool without body support	2000-105-3			\$606		
<i>Ultra stools are not sold without backs due to the tilt feature of the seat and back</i>						
Economy doctor's stool with 16" round seat	2000-103-2				\$354	
Economy doctor's stool without back with round seat	2000-103-3				\$295	
Economy assistant's stool without body support	2000-102-2					\$431
Economy assistant's stool with backrest	2000-102-3					\$755
Five point 21" base - powder coated cast aluminum			❖	❖		
Five point 22" molded plastic base					❖	❖
Synchronized seat and back tilt with quick adjustment paddles			❖	❖		
Vertical back adjustment			❖	❖		
Dual wheel, non-marring casters			❖	❖		
Dual wheel barrel casters					❖	❖
Three year warranty			❖	❖	❖	❖
19" wide contoured seat			❖		❖	
16" wide contoured back			❖	❖		
Horizontal and vertical back adjustment with knobs					❖	
Swing body support with adjustable height				❖		❖
Ratcheting quick release for entry and exit				❖		
Adjustable for right or left hand use				❖		❖
Adjustable foot ring				❖		❖
Height adjustment			20" to 25"	24.5" to 31"	17" to 22"	22.5" to 30"
FACTORY OPTIONS	PART NO.	PRICE				
Ultraleather upholstery upgrade	1006	\$162	❖	❖	❖	❖
"D" seat in lieu of round	8003-199	\$134		❖		❖
Assistant's cylinder (Ultra)	8000-017-1	\$82 or in lieu of	❖			
Doctor's cylinder (Ultra)	8000-018-1	\$82 or in lieu of		❖		
Assistant's cylinder (Economy)	8000-017	\$82 or in lieu of			❖	
Doctor's cylinder (Economy)	8000-018	\$82 or in lieu of				❖
Adjustable armrests for Doctor stool	2000-236	\$308	❖		❖	
Adjustable foot ring (Ultra)	8003-214	\$94	❖			
Adjustable foot ring (Economy)	8000-003	\$94			❖	
Replacement metal torso knob for prior style swing and stand tube	7002-342	\$22		❖		❖
Large backrest adjustment knob (specify grey or tan)	8003-202	\$13	❖	❖		
Ratchet mechanism for Deluxe and old style Ultra stools	8000-021	\$323		❖		
Casters for plastic base (specify grey or tan) - priced per caster, 5 needed per base	8000-002	\$6			❖	❖
Casters for metal base - non-marring - priced per caster, 5 needed per base	8000-033	\$9	❖	❖		
Plastic Ultra stool back cover	8002-020	\$102	❖	❖		

Upholstery Package Components for Field Installation

Pelton & Crane Chairman	\$1141	9000-001	Chair Components:		
Pelton & Crane Coachman	\$1141	9000-011	Chairman/Coachman Headrest Pillow	\$196	9003-015
Adec 1005 (Snap)	\$1141	9000-010	Chairman Telescoping Headrest	\$184	9002-007
Adec 1005 (Bolt)	\$1141	9000-010-1	Coachman Telescoping Headrest	\$184	9003-071
Belmont/Healthco Celebrity (Black)	\$1246	9000-013	Adec1005 Headrest	\$184	9002-025
Belmont/Healthco Celebrity (White)	\$1246	9000-013-1	Celebrity Headrest	\$210	9003-096
Den-Tal-Ez Advantage (add core charge)	\$1378	9000-021	Chairman/Coachman Artic. H/R (Bolt)	\$263	9003-114
Core Charge (Advantage only)	\$400	1004	Chairman/Coachman Art. H/R(Velcro)	\$263	9003-110
Adec 1020	\$1246	9000-019	Westar Articulating H/R cushion	\$80	7005-041
W2000 (Screw on style Back)	\$900	7005-091	Chairman Arm (each arm)	\$131	9002-005
Westar Asepsis (Slide on Back)	\$900	7005-700	Coachman Arm (each arm)	\$131	9003-076
Westar Plush (Slide on Back)	\$1438	7005-703	Coachman Arm Support (each elbow)	\$131	9003-074
Westar Sling Plush Style	\$1438	7005-706	Chairman Backfiller (Right)	\$74	9003-007
Westar Sling Asepsis Style	\$1000	7005-709	Chairman Back filler (Left)	\$74	9003-008
OS III	\$1238	7000-535	OS-III Arm (each arm pad, no pillow)	\$158	7000-115
Pelton & Crane Front Row Doctor	\$341	9000-002	Adec Arm slings (Snap back)	\$184	9002-039
Pelton & Crane Front Row Assistant	\$341	9000-003	Adec Arm slings (Bolt back)	\$184	9002-040
Pelton & Crane Act II Doctor	\$341	9000-004	Chairman Backrest	\$604	9000-018
Pelton & Crane Act II Assistant	\$341	9000-005	Coachman Backrest	\$604	9003-069
Adec 1600 Doctor	\$341	9000-006	Adec Back(Snap) (incl. slings)	\$604	9003-051
Adec 1620 Assistant	\$341	9000-007	Adec Back(Bolt) (incl. slings)	\$604	9003-075
Westar Deluxe Doctor	\$341	8000-100	Celebrity (Black) Backrest	\$604	9003-091
Westar Deluxe Assistant	\$341	8000-101	Celebrity (White) Backrest	\$604	9003-111
Westar Economy Doctor	\$341	8000-103	W2000 Backrest (Screw on style)	\$604	7005-001
Westar Economy Assistant	\$341	8000-102	Westar Back Asepsis Slide on	\$604	7005-060
Westar Ultra Doctor	\$341	8000-104	Westar Back Plush	\$1103	7005-704
<u>Westar Ultra Assistant</u>	<u>\$341</u>	<u>8000-105</u>	Westar Back Plush Sling	\$1103	7005-707
Stool Recovery	\$354	9000-014	Westar Back Asepsis Sling	\$704	7005-715
Front Row Dr/Asst. Seat	\$236	9002-016	Chairman Seat	\$788	9003-016
Front Row Backrest	\$236	9002-017	Coachman Seat	\$800	9003-070
Front Row Body Support	\$236	9002-018	Adec 1005 Seat	\$800	9003-052
Act II Dr/Asst Seat	\$236	9002-022	Celebrity Seat	\$893	9003-092
Act II Backrest	\$236	9002-023	Westar Seat Asepsis	\$788	7005-061
Act II Body Support	\$236	9002-024	Westar Seat Plush	\$1155	7005-705
Adec 1600/1620 Seat	\$236	9002-027	Chairman Toecover	\$74	9002-003
Adec 1600 Backrest	\$236	9002-028	Coachman Toecover	\$74	9003-073
Adec 1620 Body Support	\$236	9002-029	Adec Toecover	\$74	9002-026
Westar Ultra Doctor Seat	\$236	8005-002	Celebrity Toecover	\$74	9003-120
Westar Ultra Back	\$236	8005-001	Westar Toecover	\$74	7000-065
Westar Ultra 16" Round	\$236	8005-003			
Westar Ultra Torso	\$236	8005-004	Misc. Vinyl per yard	\$47	5003-003
Westar Doctor Contoured Seat	\$236	8003-089	Misc. Ultraleather or Finesse per yard	\$263	5003-338
Westar Stool Back	\$236	8003-069			
Westar 15" Round Seat	\$236	8003-039			
Westar Torso(Body support) new style	\$236	8005-004			
Westar Torso (Body support)old style	\$236	8003-119			
Westar "D" shaped seat	\$236	8003-199			
Ultraleather, Luxor, or Finesse Vinyl Upcharges (Not plush styling on upholstery):			Estimated shipping dimensions and weights		
Complete Chairs	\$404	1005	Chair Upholstery -	47L x 11W x 23H	30 lbs. (70lbs U.P.S)
Stools and Component Parts	\$162	1006	Stool Upholstery -	20L x 20W x 8H	11 lbs.

Pelton & Crane Front Row (A1) and Act II Stools

Retail Price: **\$341**

F/R Dr., Order# 9000-002; F/R Asst., Order# 9000-003

Act II Dr., Order# 9000-004; Act II Asst., Order# 9000-005



Pelton & Crane Chairman

Retail Price: **\$1141**

Order# 9000-001

Pelton & Crane Coachman

Retail Price: **\$1141**

Order# 9000-011

Adec 1020
Retail Price: **\$1246**
Order# 9000-019

Adec 1005
Retail Price: **\$1141**
Snap Back, Order# 9000-010
Bolt Back, Order# 9000-010-1

Den-Tal-Ez Advantage
(Not Pictured)
Retail Price: **\$1378**
Order# 9000-020
Plus Core Charge of
\$400 Order# 1004

Belmont/ Healthco Celebrity
Retail Price: **\$1246**
Black Back, Order# 9000-013
White Back, Order# 9000-013-1

WESTAR ❖
Medical Products

Adec 1600 and 1620 Stools
Retail Price: **\$341**
1600 Dr., Order# 9000-006
1620 Asst., Order# 9000-007

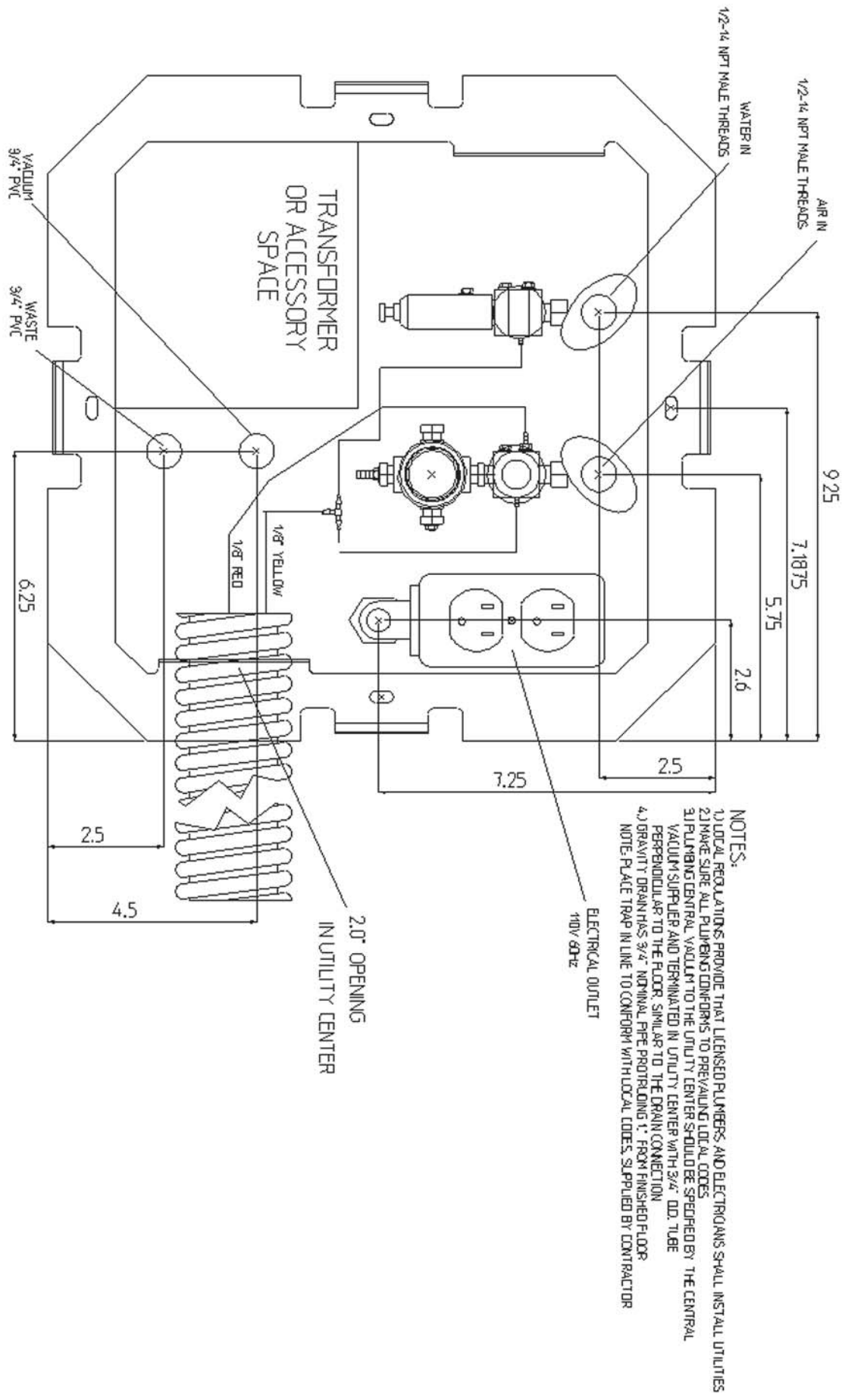

Dimensions and Specifications

Excursion Delivery Systems

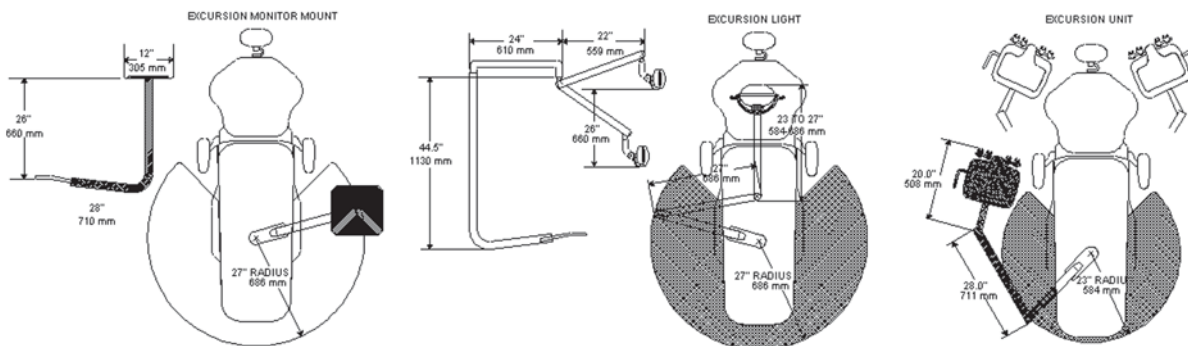

Estimated shipping dimensions and weights:
 Chair - 40L x 32W x 30H 300 lbs. plus
 Upholstery - 47L x 11W x 23H 30 lbs.
 Delivery & Light - 48L x 32W x 20H 80 lbs.

Nautica Delivery Systems

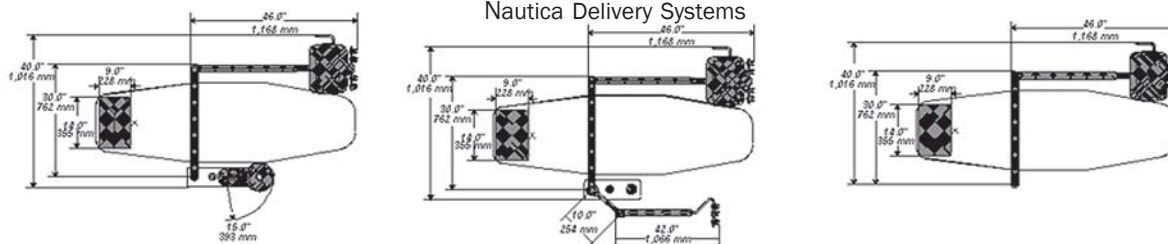

6000, 4020 and Euro Delivery Systems

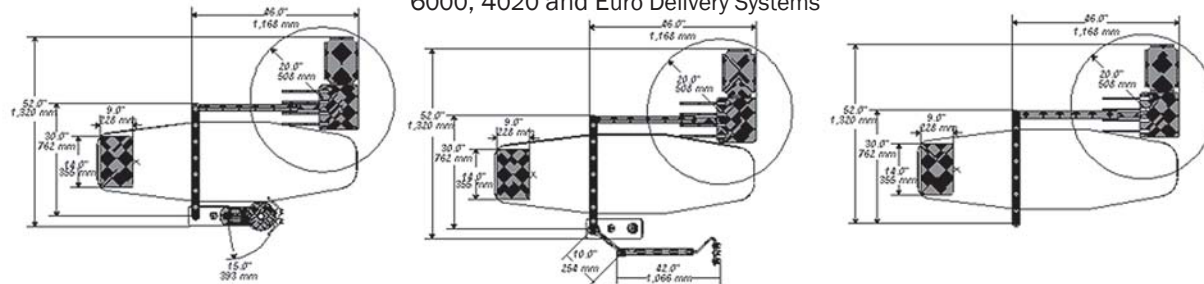

Estimated shipping dimensions and weights:
 Hydraulic Chair - 41L x 31W x 28H 330 lbs. plus upholstery
 Electromechanical Chair - 41L x 31W x 28H 300 lbs. plus upholstery
 Ortho Chair - 41L x 31W x 28H 300 lbs. plus upholstery
 Upholstery - 47L x 11W x 23H 30 lbs.
 Control Head - 37L x 22W x 14H 42 lbs.
 Cuspidor - 32L x 23W x 16H 39 lbs.
 Assistant - 32L x 23W x 16H 25 lbs.
 42" Pole - 47L x 2W x 2H 5 lbs.
 Chair adaptor - 20L x 8W x 8H 15 lbs.
 Light - 33L x 17W x 14H 22 lbs.
 D5000 - UPS: 22L x 22W x 16H LTL: 22L x 22W x 30H 26 lbs
 A5000 - UPS: 22L x 22W x 30H LTL: 22L x 22W x 30H 39 lbs
 D2000E - UPS: 22L x 22W x 16H LTL: 22L x 22W x 30H 25 lbs
 A2000E - UPS: 22L x 22W x 30H LTL: 22L x 22W x 30H 31 lbs

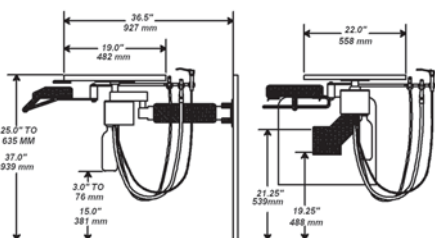

4066 Wall Mount Duo Power Arm

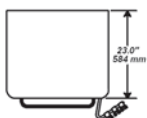

Estimated shipping dimensions and weights:
 Duo - 29L x 17W x 12H 26 lbs

Westar Medical Products, Inc.

Phone: 425/290-3945 ✦ Watts: 800/499-3945 ✦ Fax: 425/356-2961

6600 Merrill Creek Parkway, Suite 206 ✦ Everett, WA 98203

Email: westar_medical@msn.com ✦ Website: www.westarmedicalproducts.com

May 2006

\$10.00 U. S. D.